



L&C

LABELING
& CODING

MFLEX™ TOP & BOTTOM PRESSURE-SENSITIVE LABEL APPLICATOR SYSTEM



Engineered for Modularity and Flexibility

Building on the many years of experience and engineering expertise within ProMach Labeling & Coding, the MFlex is a completely new, modular, and flexible pressure-sensitive labeling system.

MFlex Top & Bottom labelers are designed to label the top and/or bottom of all product packaging neatly and accurately. It features vertical and horizontal adjustments to allow for quick and reliable label placement.

Composed of two label applicators and integrated product handling solution, the MFlex precisely labels a variety of packaging shapes and product types that provides an easy and flexible platform to not only control, but maintain.

Because the M2 labeling heads can be independently switched on or off, the system can also be used for top-only or bottom-only labeling as needed.

FEATURES AND BENEFITS

- Closed-loop electric servo system to ensure maximum synchronization and control
- Singular full color touch-screen HMI provides fast access to any adjustments as well as full diagnostics for maintenance.
- Built on a welded stainless steel frame, using non-corrosive components that feature IP65 protection.
- Modular components for maximum serviceability.
- Tool-free design for easy and fast adjustments.
- Compact high-powered brushless DC conveyor and product handling motors.
- Zero downtime option featuring redundant labeling heads for continuous labeling production.

COMMON APPLICATIONS





MFLEX™ TOP & BOTTOM PRESSURE-SENSITIVE LABELING SYSTEM

STANDARD PRODUCT SPECIFICATIONS

Label Supply	12" Diameter / 3" Core		Electrical	120V AC @ 6A, 60Hz
Label Size	Min: 1" x 2" Feed	Max: 5" x 12" Feed	Conveyor Speed	Variable up to 125ft per minute
Product Size	4" to 12" Wide	2" to 24" long	Conveyor	Stainless Steel, Aluminum, UHMW
Operation	Closed-loop Electric Servo		IP Rating	IP65 Wet/Damp Environment

CONFIGURATION

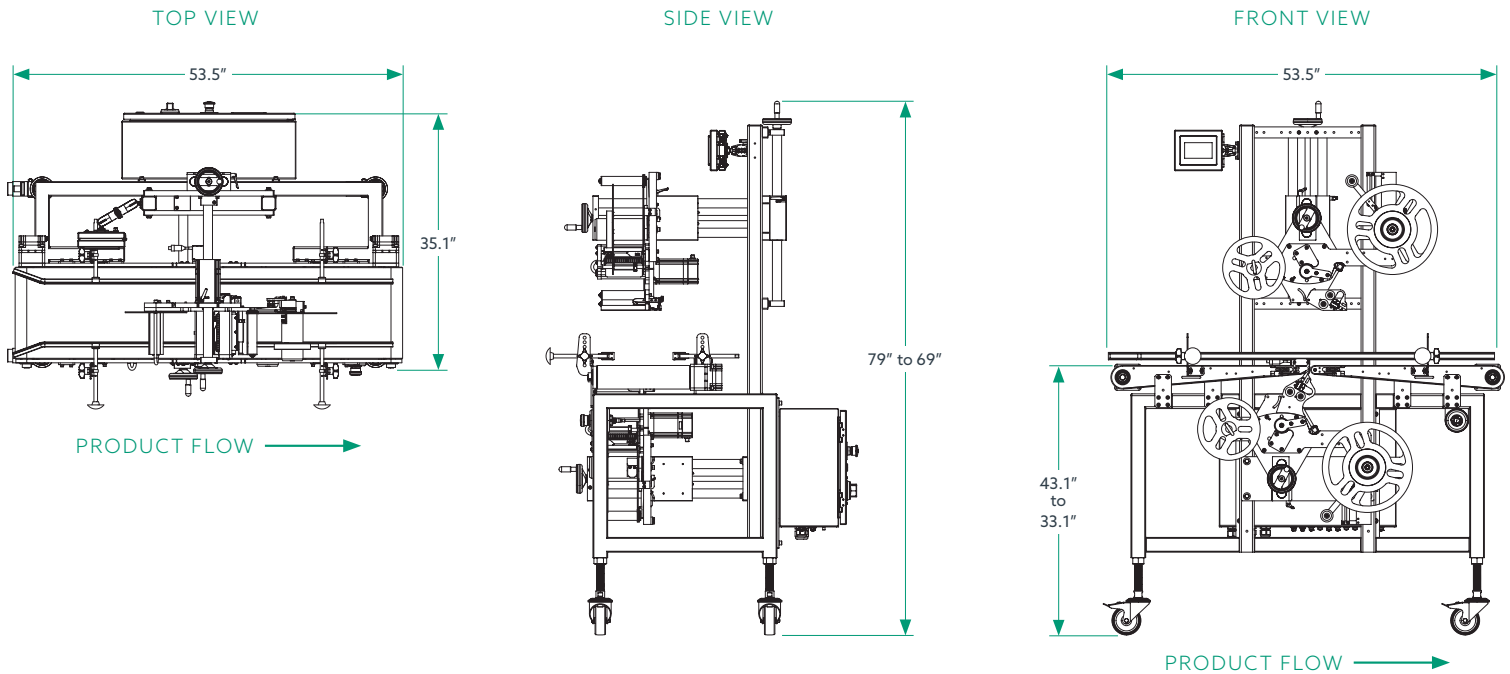

SYSTEM OPTIONS

- 16" (407mm) OD Label Supply
- Increased Label Width
- Low Label Supply Warning with Auto Shut-Off Feature and Beacon light
- Different Supply Voltage
- Clear Label Sensor Package
- Additional Conveyor Width
- Additional Conveyor Length
- Adjustable Feet
- Higher Speed

©2022 ProMach Inc. ProMach reserves the right to change or discontinue specifications and designs shown in this brochure without notice or recourse
EPI_SpecSheet_MFlex Top-Bottom_030322



PHONE
717-235-8345

TOLL FREE
800-755-8344

EMAIL
EPI@ProMachBuilt.com

WEB
EPILabelers.com

1145 East Wellspring Rd
New Freedom, PA 17349